

*Antriebs-Kupplungen*



*Drive Couplings*



**SOFTEX® ELASTISCHE UND DREHSPIELFREIE WELLENKUPPLUNGEN**  
**SOFTEX® ELASTIC AND NO BACKLASH SHAFT COUPLINGS**

**SOFTEX®-STANDARD KUPPLUNGEN**  
**SOFTEX®-STANDARD COUPLINGS**

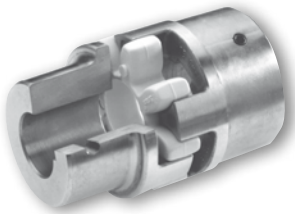

- Drehelastisch, wartungsfrei
  - Schwingungsdämpfend
  - Axial steckbar
  - Allseitig bearbeitet – gute dynamische Eigenschaften
  - Kompakt bauend / niedrige Schwungmomente
  - Lieferbare Materialien der Naben: Aluminium, Grauguss (EN-GJL-250), Sphäroguss (EN-GJS-400-15), Sinterstahl und Stahl
  - Verschiedene Elastomerhärten der Zahnkränze
  - Bohrungsdurchmesser zylindrisch (metrisch / Zoll), konisch oder verzahnt nach DIN oder SAE-Norm lieferbar
- Torsionally flexible, maintenance-free
  - Vibration reducing
  - Axially pluggable
  - Machined all over – good dynamic properties
  - Compact design / low flywheel effects
  - Available hub materials: Aluminium, cast iron (EN-GJL-250, spheroidal cast iron (EN-GJS-400-15), sintered steel and steel
  - Different elastomer hardness of the gear rings
  - Bore diameter cylindrical (metric/inch), available tapered or splined acc. to DIN SAE standard

**SOFTEX®-ES SPIELFREIE KUPPLUNGEN**  
**SOFTEX®-ES NO BACKLASH COUPLINGS**



- Unter Vorspannung spielfreie Wellenverbindung
  - Werkstoff: Naben Aluminium
  - Verschiedene Elastomerhärten der Zahnkränze
  - 3-teilige einfachkardanische Kupplung
  - Axial steckbar – einfache Blindmontage, keine zeitaufwändigen Verschraubungen
  - Kleine Baumaße – geringe Schwungmomente
  - Wartungsfrei
  - Einfache optische Prüfung
  - Lieferbar für alle üblichen Wellenabmessungen
  - Fertigbohrungen nach ISO-Passung H7, (Klemmnabe F7), Passfedernute ab Ø 6 nach DIN 6885 Bl. 1-JS9
- Under initial tension no backlash shaft connection
  - Material: Hubs made of aluminium
  - Different elastomer hardness of the gear rings
  - Triple simple cardanic coupling
  - Axially pluggable – simple blind mounting, no time-consuming screwings
  - Small structural dimensions – low flywheel effects
  - Maintenance-free
  - Simple optical test
  - Available for all usual shaft dimensions
  - Finish bores acc. to ISO limit and fit H7 (clamp hub F7) keyway from Ø 6 acc. to DIN 6885 P.1-JS9

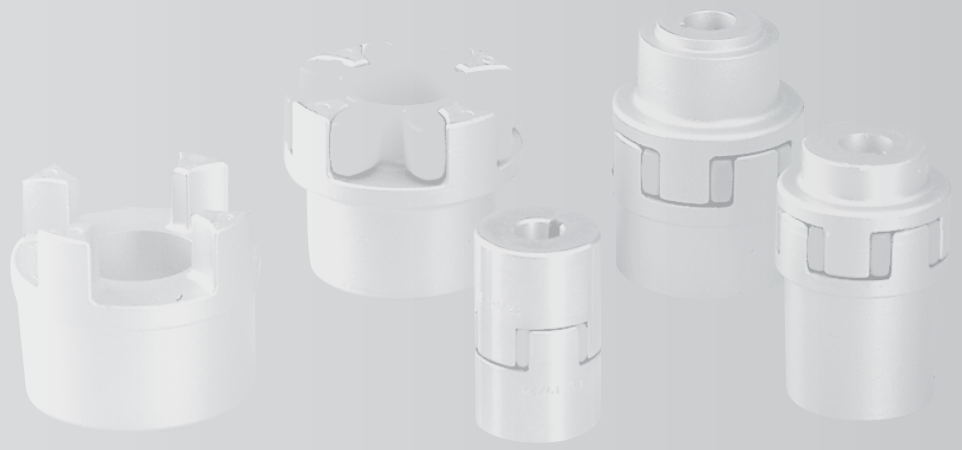

## **SOFTEX®-TL MIT TAPER-KLEMMBUCHSE** **SOFTEX® -TL WITH TAPER BUSH**



- Für alle Antriebsfälle im Bereich des Maschinenbaues
- Reibschlüssige, lösbare Wellen/Nabenverbindungen
- Kupplungskombination TL 1/1; TL 2/2 und TL 1/2 möglich
- Kupplungsnaben TL 2 axial trennbar
- Einsetzbar mit allen Standard Taper-Klemmbuchsen
- For all driving applications concerning mechanical engineering
- Friction-locked solvable shafts/hub connections
- Coupling types TL 1/1; TL 2/2 and TL 1/2 possible
- Coupling hubs TL 2 axially separable
- Application with all standard taper bushes

## **SOFTEX®- FA FLANSCHKUPPLUNGEN** **SOFTEX® FA FLANGE COUPLINGS**

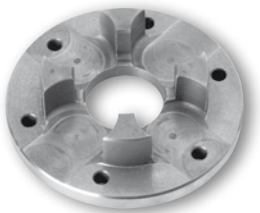

- Flanschnaben für den Schwermaschinenbau
- Alle Größen sind flanschseitig unbearbeitet und montagefertig bearbeitet lieferbar
- 2-Flansche kombinierbar oder FA Flansch mit Standard Softex®-Nabe
- Werkstoff: Grauguss (EN-GJL-250)
- Flange hubs for heavy machinery
- All sizes are unmachined on the flange side and available ready for assembly
- 2 flanges can be combined or FA flange with standard Softex® hub
- Material: Cast Iron (EN-GJL-250)

# SOFTEX®-STANDARD KUPPLUNGEN (DREHELASTISCHE KUPPLUNGEN)

## SOFTEX®-STANDARD COUPLINGS (ELASTIC COUPLINGS)

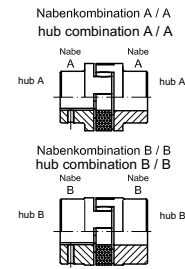
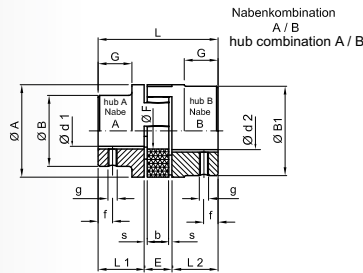
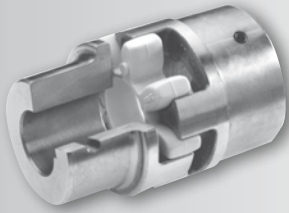

### PRODUKTBESCHREIBUNG

- Drehelastisch, wartungsfrei
- Schwingungsdämpfend
- Axial steckbar
- Allseitig bearbeitet – gute dynamische Eigenschaften
- Kompakt bauend/ niedriges Schwungmomente

### PRODUCT DESCRIPTION

- Torsionally flexible, maintenance-free
- Vibration reducing
- Axially pluggable
- Machined all over – good dynamic properties
- Compact design/ low flywheel effects

### WERKSTOFF: ALUMINIUM- DRUCKGUSS

### MATERIAL: DIE CAST ALUMINIUM

TYP SIZE	NABE/HUB A		NABE/HUB B		ABMESSUNGEN/DIMENSIONS (MM)														VERLÄNGERTE B-NABEN EXTENDED B-HUBS max. mm	GEWICHT <sup>2)</sup> WEIGHT (KG) KOMBINATION COMBINATION A/B
	VORBOHRUNG PREBORE	FERTIGBOHRUNG <sup>1)</sup> FINISH BORE D = Ø	VORBOHRUNG PREBORE	FERTIGBOHRUNG <sup>1)</sup> FINISH BORE D = Ø	A	B	B <sub>1</sub>	L	L <sub>1</sub> +L <sub>2</sub>	E	s	b	G	F	g	f				
																	min	max		
19/24 Aluminium	6	6	19	18	20	24	40	31	38	66	25	16	2	12	20	18	M5	10	-	0,11
24/30 Aluminium	6	8	24	22	25	30	55	39	48	78	30	18	2	14	24	27	M5	10	50	0,24
28/38 Aluminium	9	10	28	26	30	38	65	46	61	90	35	20	2,5	15	28	30	M6	15	60	0,42
38/45 Aluminium	12	14	38	36	40	45	80	64	75	114	45	24	3	18	37	38	M8	15	-	0,86

### WERKSTOFF: GG = GUSSEISEN (DIN EN 1561/1563)

### MATERIAL: GG = CAST IRON (DIN EN 1561/1563)

### S = SINTERSTAHL

### S = SINTERED STEEL

### ST = STAHL

### ST = STEEL

TYP SIZE	NABE/HUB A		NABE/HUB B		ABMESSUNGEN/DIMENSIONS (MM)														VERLÄNGERTE B-NABEN EXTENDED B-HUBS max. mm	GEWICHT <sup>2)</sup> WEIGHT (KG) KOMBINATION COMBINATION A/B
	VORBOHRUNG PREBORE	FERTIGBOHRUNG <sup>1)</sup> FINISH BORE D	VORBOHRUNG PREBORE	FERTIGBOHRUNG <sup>1)</sup> FINISH BORE D	A	B	B <sub>1</sub>	L	L <sub>1</sub> +L <sub>2</sub>	E	s	b	G	F	g	f				
																	min	max		
14/16 S	-	-	-	-	4	16	30	-	30	35	11	13	1,5	10	-	8	M4	5	-	0,14
19/24 S	-	-	-	-	6	24	40	-	40	66	25	16	2	12	-	18	M5	10	40	0,34
24/30 S	-	-	-	-	8	32	55	-	55	78	30	18	2	14	-	27	M5	10	50	0,90
28/38 S	-	-	-	-	10	38	65	-	65	90	35	20	2,5	15	-	30	M6	15	60	1,5
38/45 GG	-	14	38	-	40	45	80	66	78	114	45	24	3	18	37	38	M8	15	70	2,35
42/55 GG	-	16	42	-	45	55	95	75	93	126	50	26	3	20	40	46	M8	20	75	3,55
48/60 GG	-	19	48	-	50	60	105	85	103	140	56	28	3,5	21	45	51	M8	20	80	4,85
55/70 GG	-	22	55	53	60	70	120	98	118	160	65	30	4	22	52	60	M10	20	90	7,4
65/75 GG	-	25	65	63	70	75	135	115	133	185	75	35	4,5	26	61	68	M10	20	100	10,8
75/90 GG	-	30	75	73	80	90	160	135	158	210	85	40	5	30	69	80	M10	25	110	17,7
90/100 GG	-	-	-	-	45	100	200	-	170	245	100	45	5,5	34	81	100	M10	25	-	29,6
100/110 ST	-	-	-	-	45	110	225	-	180	270	110	50	6	38	89	113	M12	30	-	39,0
110/125 ST	-	-	-	-	60	125	255	-	200	295	120	55	6,5	42	96	127	M16	35	-	55,0
125/145 ST	-	-	-	-	60	145	290	-	230	340	140	60	7	46	112	147	M16	40	-	77,0

1) Fertigbohrungen nach ISO- Passung H 7, Passfedernut nach DIN 6885, Blatt 1-JS9, konische Bohrungen siehe Seite 6.

2) Gewichte beziehen sich auf die Werkstoffe Aluminium/ GG bei max d<sub>i</sub> ohne Nut.

1) Finish bores acc. to ISO- standard H 7, keyway acc. to DIN 6885, sheet 1- JS9, taper bores page 6.

2) Weights refer to materials aluminium/

## TECHNISCHE DATEN

## TECHNICAL DATA

ZAHNKRANZ POLYURETHAN POLYURETHANE SPIDER	KUPPLUNGSTYPEN FÜR ALLE WERKSTOFFE COUPLING TYPES FOR ALL MATERIALS	DREHMOMENT TORQUE (Nm)			ZAHNKRANZ POLYURETHAN POLYURETHANE SPIDER	DREHMOMENT TORQUE (Nm)			ZAHNKRANZ POLYURETHAN POLYURETHANE SPIDER	DREHMOMENT TORQUE (Nm)			MAX. DREHZAHL <sup>1)</sup> SPEED [1/MIN] BEI V/ATV	
		NENN CONT. TKN	MAX. TK MAX.	WECHSEL ALTER- NATING TKW		NENN CONT. TKN	MAX. TK MAX.	WECHSEL ALTER- NATING TKW		NENN CONT. TKN	MAX. TK MAX.	WECHSEL ALTER- NATING TKW	30 m/s	40 m/s
80° Shore A Farbe: blau	14/16	4	8	1	92° Shore A Farbe: weiß	7,5	15	2	98° Shore A Farbe: rot	12,5	25	3,3	19000	-
	19/24	4,9	9,7	1,3		10	20	2,6		17	34	4,4	14000	19000
	24/30	17	34	4,4		35	70	9		60	120	16	10600	14000
	28/38	46	92	12		95	190	25		160	320	42	8500	11800
80° shore A colour: blue	38/45	93	186	24	92° shore A colour: white	190	380	49	98° shore A colour: red	325	650	85	7100	9500
	42/55	130	260	34		265	530	69		450	900	120	6000	8000
	48/60	150	300	39		310	620	81		525	1050	137	5600	7100
	55/70	180	360	47		375	750	93		625	1250	163	4750	6300
	65/75	205	410	53		625	850	111		900	1300	169	4250	5600
	75/90	475	950	124		975	1950	254		1500	3000	390	3550	4750
	90/100	1175	2350	306		2400	4800	624		3600	7200	963	2800	3750
	100/110	-	-	-		3300	6600	858		4950	9900	1287	2500	3350
110/125	-	-	-	4000	8000	1040	6000	12000	1560	2240	3000			
125/145	-	-	-	5000	10000	1300	7500	15000	1950	2000	2650			

## VERLAGERUNGSWERTE

## MISALIGNMENT VALUES

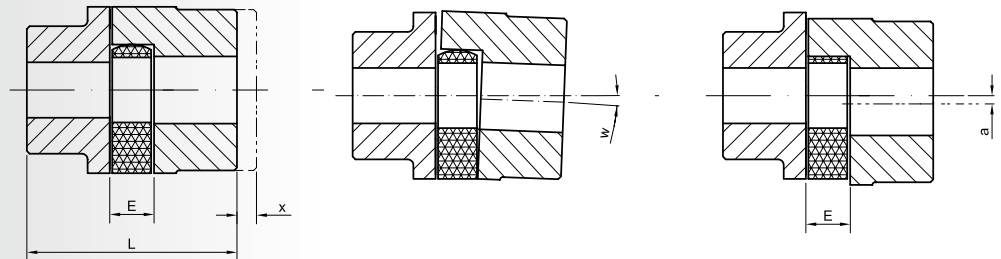

Axialverschiebung  
Axial displacement

Winkelverschiebung oder  
Angular displacement or

Radialverschiebung  
Radial displacement

TYP SIZE	E	MAX. AXIALVERSCHEIBUNG* MAX. AXIAL DISPLACEMENT* [mm] x	MAX. WINKELVERLAGERUNG w bei 1500 (1/min) oder MAX. ANGULAR DISPLACEMENT w 1500 (1/min) or	MAX. RADIALVERLAGERUNG bei 1500 (1/min) [mm] a MAX. RADIAL DISPLACEMENT 1500 (1/min) [mm] a
14/16	13	1,0	0,9°	0,17
19/24	16	1,2	0,9°	0,2
24/30	18	1,4	0,9°	0,22
28/38	20	1,5	0,9°	0,25
38/45	24	1,8	1°	0,28
42/55	26	2,0	1°	0,32
48/60	28	2,1	1,1°	0,36
55/70	30	2,2	1,1°	0,38
65/75	35	2,6	1,2°	0,42
75/90	40	3,0	1,2°	0,48
90/100	45	3,4	1,2°	0,50
100/110	50	3,8	1,2°	0,52
110/125	55	4,2	1,3°	0,55
125/145	60	4,6	1,3°	0,60

\*Bei Axialverlagerungen dürfen die Maße „E“ und „L“ nur um die angegebenen Werte überschritten werden.

\*In case of axial misalignment the factors "E" and "L" are the max. values.

Bei der Kupplungsmontage ist darauf zu achten, dass das E-Maß genau eingehalten wird, damit die Kupplung axial beweglich bleibt. Sorgfältiges Ausrichten der Wellen erhöht die Lebensdauer der Kupplung. Die Verlagerungswerte sind drehzahl- und leistungsabhängig.

When mounting the coupling, dimension "E" must be observed exactly in order to keep the coupling axially flexible. The stability of the coupling will be increased by careful alignment of the shafts. The displacement values depend on torque speed and performance.

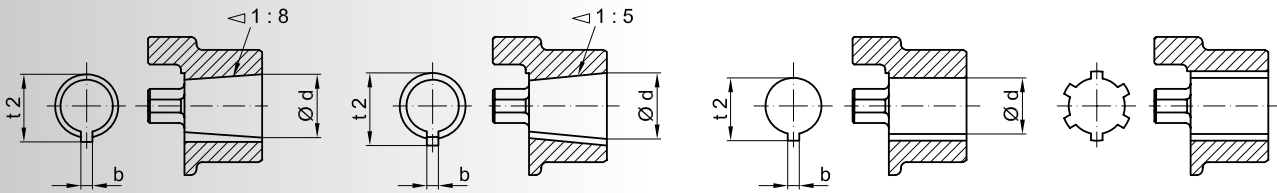

**KEGEL / TAPER 1:8**

CODE	BOHRUNGSANGABEN BORE DETAILS			
	d <sub>σ</sub> +0,05	b +0,05	t <sub>z</sub> +0,1	L
... N/1	9,7	2,4	10,7	17
... N/1c	11,6	3	12,9	16,5
... N/1e	13	2,4	13,8	21
... N/1d	14	3	15,5	17,5
... N/1b	14,3	3,2	15,7	19,5
... N/2	17,2	3,2	18,3	24
... N/2a	17,2	4	19,0	24
... N/2b	17,2	3	18,4	24
... N/3	22	4	23,5	28
... N/4	25,4	4,78	27,8	36
... N/4b	25,4	5	28,2	36
... N/4a	27	4,78	28,8	32,5
... N/4g	28,45	6	29,3	38,5
... N/5	33	6,35	35,5	44
... N/5a	33	7	35,5	44
... N/6	43,05	7,95	46,5	51
... N/6a	41,15	8	44,2	42,5

**KEGEL / TAPER 1:5**

CODE	BOHRUNGSANGABEN BORE DETAILS			
	d <sub>σ</sub> +0,05	b js 9	t <sub>z</sub> +0,1	L
... A 10	9,85	2	10,85	11,5
... B 17	16,85	3	18,65	18,5
... C 20	19,85	4	22,05	21,5
... Cs 22	21,95	3	23,75	21,5
... D 25	24,85	5	27,75	26,5
... E 30	29,85	6	32,45	31,5
... F 35	34,85	6	37,45	36,5
... G 40	39,85	6	42,45	41,5

**ZOLLBOHRUNGEN / INCH BORES**

CODE	METRISCH (mm) METRIC (mm)			ZOLL INCH	
	dØ	b+0,05	t <sub>z</sub> +0,1	dØ	b
V	11,11 + 0,03	3,2	12,6	7/16	1/8
Ta	12,7 + 0,03	3,2	14,3	1/2	1/8
E	15,87 + 0,03	3,2	17,5	5/8	1/8
Ed	15,87 + 0,03	4,75	18,1	5/8	3/16
Ad	19,02 + 0,03	3,2	20,7	3/4	1/8
A	19,05 + 0,03	4,78	21,3	3/4	3/16
Gs	22,22 + 0,03	4,78	24,4	7/8	3/16
G	22,22 + 0,03	4,75	24,7	7/8	3/16
F	22,22 + 0,03	6,35	25,2	7/8	1/4
B	25,37 + 0,03	4,78	27,8	1	3/16
Bs	25,38 + 0,03	6,37	28,3	1	1/4
SB	28,58 + 0,03	6,35	31,5	1 1/8	1/4
Sd	28,58 + 0,03	7,93	32,1	1 1/8	5/16
Js	31,75 + 0,03	6,35	34,6	1 1/4	1/4
J	31,75 + 0,03	7,93	34,4	1 1/4	5/16
K	31,75 M7	7,93	35,5	1 1/4	5/16
M	34,92 + 0,03	7,93	38,6	1 3/8	5/16
C	38,07 + 0,03	9,55	42,5	1 1/2	3/8
N	41,25 + 0,03	9,55	45,6	1 5/8	3/8
L	44,45 K7	11,11	49,4	1 3/4	7/16
NM	47,625 + 0,03	12,73	53,5	1 7/8	1/2
P	53,95 + 0,03	12,73	59,6	2 1/8	1/2
U	57,1 + 0,03	12,73	62,9	2 1/4	1/2
UB	60,3 + 0,03	15,87	67,6	2 3/8	5/8
W	69,85 M7	15,875	77,3	2 3/4	5/8
WA	73,0 + 0,03	19,05	81,7	2 7/8	3/4
WD	85,725 M7	22,225	95,8	3 3/8	7/8

Vor den Code ist die jeweilige Kupplungsgröße zu setzen: z. B. 24/30 N/2a

This size of coupling should be inserted before the code: e.g. 24/30 N/2a

Für Profile nach DIN und SAE sowie Zollbohrungen bitte separate Liste anfordern.

For splines acc. to DIN and SAE as well as for inch bores please ask for separate list.

# BASISSORTIMENT ZYLINDRISCHE UND KONISCHE BOHRUNGEN

## BASIC PROGRAMME METRIC AND CONICAL (TAPER) BORES

SOFTEX® TYP / SIZE MATERIAL		KEGEL / TAPER 1:5				KEGEL / TAPER 1:8					ZOLLBOHRUNGEN / INCH BORES																			
		A 10	B17	C20	D25	N/1	N1d	N/2	N/2a	N/3	A	B <sub>s</sub>	C	Ed	Es	F	G	K	L	M	N	NIM	P	S <sub>b</sub>	S <sub>d</sub>	T <sub>a</sub>	WA	WD		
19/24	Alu-D	•				•	•				•					•												•		
	S	•				•	•				•					•														
24/30	Alu-D	•	•	•	•	•	•	•	•	•	•	•	•	•	•	•	•							•						
	S		•	•	•			•	•	•	•	•	•	•	•	•	•													
28/38	Alu-D		•	•	•			•	•	•	•	•	•	•	•	•	•							•			•			
	S		•	•	•			•	•	•	•	•	•	•	•	•	•													
38/45	Alu-D		•		•			•	•	•	•	•	•	•	•	•	•													
	GG		•		•			•	•	•	•	•	•	•	•	•	•					•								
42/55	GG		•		•			•	•	•	•	•	•	•	•	•	•													
48/60	GG														•															
55/70	GG																													
65/75	GG																													
75/90	GG																													

SOFTEX® TYP / SIZE MATERIAL		NABE / HUB	FERTIGBOHRUNGEN ISO-PASSUNG H7, NUT NACH DIN 6885, BLATT 1 FINISH BORES ACC. ISO-STANDARD H7, KEYWAY ACC. DIN 6885, SHEET 1																																			
			6	8	9	10	11	12	14	15	16	18	19	20	22	24	25	28	30	32	35	38	40	42	45	48	50	55	60	65	70	75	80	85	90	95	100	
19/24	AWD	A	•	•	•	•	•	•	•	•	•	•	•	•	•	•	•	•	•	•	•	•	•	•	•	•	•	•	•	•	•	•	•	•	•	•	•	•
		B																																				
	S	B				•	•	•	•	•	•	•	•	•	•	•	•	•	•	•	•	•	•	•	•	•	•	•	•	•	•	•	•	•	•	•	•	•
24/30	AWD	A			•	•	•	•	•	•	•	•	•	•	•	•	•	•	•	•	•	•	•	•	•	•	•	•	•	•	•	•	•	•	•	•	•	•
		B																																				
	S	B			•	•	•	•	•	•	•	•	•	•	•	•	•	•	•	•	•	•	•	•	•	•	•	•	•	•	•	•	•	•	•	•	•	•
28/38	AWD	A																																				
		B																																				
	S	B																																				
38/45	AWD	A																																				
		B																																				
	GG	A																																				
42/55	GG	A																																				
		B																																				
	GG	A																																				
48/60	GG	A																																				
		B																																				
	GG	A																																				
55/70	GG	A																																				
		B																																				
	GG	A																																				
65/75	GG	A																																				
		B																																				
	GG	A																																				
75/90	GG	A																																				
		B																																				
	GG	A																																				
90/100	GG	A <sub>8</sub>																																				

• Standard-Länge / Standard length      ■ B-Nabe verlängert / B-hub extended

# SOFTEX®-ES SPIELFREIE KUPPLUNGEN SOFTEX®-ES NO BACKLASH COUPLINGS

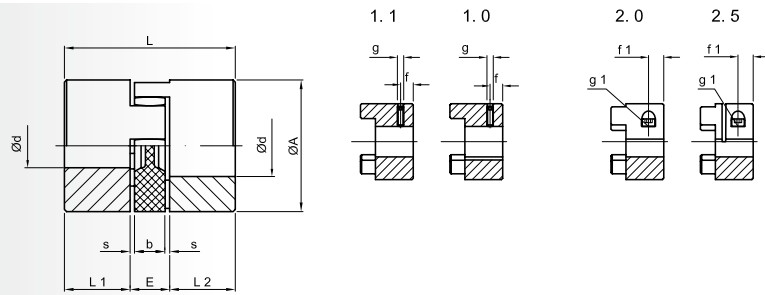

## PRODUKTBESCHREIBUNG

- Unter Vorspannung spielfreie Wellenverbindung
- Werkstoff: Naben Aluminium
- 3-teilige einfachkardanische Kupplung
- Axial steckbar - einfache Blindmontage, keine zeitaufwändigen Verschraubungen
- Kleine Baumaße - geringe Schwungmomente
- Wartungsfrei
- Einfache optische Prüfung
- Verschiedene Elastomerhärten der Zahnkränze
- Lieferbar für alle üblichen Wellenabmessungen
- Fertigbohrungen nach ISO-Passung H7, (Klemmnabe F7), Passfedernute ab Ø 6 nach DIN 6885 Bl. 1-JS9

## PRODUCT DESCRIPTION

- Under initial tension no backlash shaft connection
- Material: Hubs made of aluminium
- Triple simple cardanic coupling
- Axially pluggable - simple blind mounting, no time-consuming screwings
- Small structural dimensions - low flywheel effects
- Torsionally flexible, maintenance-free
- Simple optical test
- Different elastomer hardness of the gear rings
- Available for all usual shaft dimensions
- Finish bores acc. to ISO limit and fit H7 (clamp hub F7) keyway from Ø 6 acc. to DIN 6885 P.1-JS9

SOFTEX® ES TYP SIZE	UNGEBOHRT UNBORED	FERTIGBOHRUNGEN* FINISH BORES*				ABMESSUNGEN DIMENSIONS [mm]								KLEMMSCHRAUBE CLAMPING SCREW		
		NABENAUSFÜHRUNG HUB TYPE				A	L	L <sub>1</sub> L <sub>2</sub>	E	b	s	(1,0) (1,1) g	f	(2,0) (2,5) g <sub>1</sub>	f <sub>1</sub>	T <sub>A</sub> [Nm]
		d <sub>min</sub>	1,0 d <sub>max</sub>	1,1 d <sub>max</sub>	2,0/2,5 d <sub>max</sub>											
MAT. - ALUMINIUM																
9	x	4	9	11	11	20	30	10	10	8	1,0	M4	5	M2,5	5,0	0,76
14	x	4	15	16	16	30	35	11	13	10	1,5	M4	5	M3	5,0	1,34
19/24	x	6	24	24	20	40	66	25	16	12	2,0	M5	10	M6	12,0	10,5
24/30	x	10	30	30	28	55	78	30	18	14	2,0	M5	10	M6	10,5	10,5
28/38	x	10	38	38	38	65	90	35	20	15	2,5	M8	15	M8	11,5	25,0
38/45	x	15	45	45	45	80	114	45	24	18	3,0	M8	15	M8	15,5	25,0

\* Sonderbohrungen auf Anfrage

\* Special bores on request

## BOHRUNGSBEREICH Ød UND ZUGEHÖRIGE ÜBERTRAGBARE DREHMOMENTE (NM) DER KLEMMNABE (2.0/2.5) BORE RANGE Ø d CORRESPONDING TRANSFERABLE TORQUES (NM) OF THE CLAMPING HUB (2.0/2.5)

SOFTEX® ES	8	9	10	11	14	15	16	19	20	24	25	28	30	32	35	38	40	42	45
9	2,5	2,6	2,7	2,8															
14	5,1	5,3	5,5	5,6	8,1	6,3	6,5												
19/24	25	26	27	27	29	30	31	32	34										
24/30			34	35	36	38	39	19	41	43	45	46							
28/38					80	81	81	85	87	91	92	97	99	102	105	109			
38/45						92	94	98	99	104	105	109	112	113	118	122	123	126	130

Fertigbohrungen Nabenausführung 1.0 und 1.1 Passung H7, Ausführung 2.0 und 2.5 Passung F7 Nut nach DIN 6885. Blatt 1 Tol. JS 9

Finish bores hub types 1.0 and 1.1 limit and fit H7, types 2.0 and 2.5 limit and fit F7 Keyway acc. to DIN 6885, Page 1, Tol. JS 9

SOFTEX® ES TYP SIZE	ZAHNKRANZ SPIDER SHORE°	DREHMOMENT/TORQUE [Nm]			MAX. 1) DREHZAHL MAX. SPEED [1/MIN] V=30 m/s	STATISCHE DREHFEDERSTEIFE STATIC ELONGA- TION PER UNIT FORCE [Nm/rad]	ZUL. VERLAGERUNG BEI ADMISSIBLE MISALIGNMENT n=1500 1/min			RADIALFEDERSTEIFE RADIAL ELONGATION PER UNIT FORCE Cr [N/mm]	GEWICHT/WEIGHT [kg]	MASSENTRÄGHEITS- MOMENT J ANGULAR MOMENTUM [kg/cm²]
		TK <sub>SP</sub>	TK <sub>N</sub>	TK <sub>MAX</sub>			axial Δ ka [mm]	radial Δ kr [mm]	winkelig angular Δ kw [Grad]			
9	64D	0,45	6	12	28000	74	0,8	0,05	0,9	739	0,015	0,01
	92A		3	6		32		0,15	1,0	260	0,015	0,01
	98A (Standard)		5	10		51		0,09	0,9	520	0,015	0,01
14	64D	1	16	32	13000	234	1,0	0,06	0,8	856	0,06	0,06
	92A		7,5	15		114		0,15	1,0	335	0,06	0,06
	98A (Standard)		12,5	25		172		0,09	0,9	605	0,06	0,06
19/24	64D	2,5	21	42	10000	1240	1,2	0,04	0,8	2830	0,13	0,37
	92A		10	20		570		0,10	1,0	1120	0,13	0,37
	98A (Standard)		17	34		855		0,07	0,9	2010	0,13	0,37
24/30	64D	-	75	150	7000	2980	1,4	0,07	0,8	3696	0,28	1,35
	92A		35	70		1430		0,14	1,0	1780	0,28	1,35
	98A (Standard)		60	120		2060		0,10	0,9	2565	0,28	1,35
28/38	64D	-	200	400	6000	4350	1,5	0,09	0,8	4348	0,46	3,10
	92A		95	190		2292		0,15	1,0	1785	0,46	3,10
	98A (Standard)		160	320		3440		0,11	0,9	3200	0,46	3,10
38/45	64D	-	405	810	5000	10540	1,8	0,09	0,8	6474	0,90	9,62
	92A		190	650		4584		0,17	1,0	2350	0,90	9,62
	98A (Standard)		325	380		7160		0,12	0,9	4400	0,90	9,62

- Bei höheren Drehzahlen ist dynamisches Auswuchten der Naben erforderlich.
- Das Längenmaß L vergrößert sich um die angegebene Δ ka-Werte.
- Die aufgeführten Verlagerungswerte sind allgemeine Richtwerte.
- Bei gleichzeitigem Winkel- und Radialversatz können die angegebenen Werte nur anteilmäßig ausgenutzt werden.
- Die Tabellenwerte sind gültig für eine Betriebstemperatur T=+30°C. Bei einer Temperaturerhöhung müssen die zulässigen Drehmomente und die max. zulässigen Radial- und Winkelverlagerungswerte mit dem Temperaturfaktor St multipliziert werden.

- In case of higher speeds a dynamic balancing of the hubs is required.
- The length dimension L is increased by the indicated Δ ka values.
- The specified misalignment values are general approximate values.
- In case of current angular and radial misalignment the indicated values can only be utilized proportionately.
- The table values are valid for an operating temperature T=+30°C. In case of a temperature increase the admissible torques and the max. admissible radial and angular misalignment values must be multiplied by the temperature factor St.

TEMPERATUR TEMPERATURE	- 25 < + 30°C	+ 30 < + 40°C	+ 40 < + 60°C	+ 60 < + 80°C
FAKTOR ST FACTOR ST	1,0	0,8	0,7	0,6

# SOFTX®-TL DREHELASTISCHE KUPPLUNGEN MIT TAPER-KLEMMBUCHSE

## SOFTX®-TL ELASTIC COUPLINGS WITH TAPER BUSH

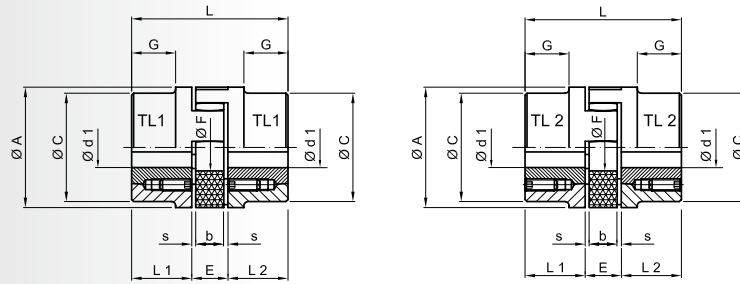

### PRODUKT-BESCHREIBUNG

- Für alle Antriebsfälle im Bereich des Maschinenbaus
- Reibschlüssige, lösbare Wellen/Nabenverbindungen
- Kupplungskombination TL 1/1; TL 2/2 und TL 1/2 möglich
- Kupplungsnaben TL 2 axial trennbar
- Einsetzbar mit allen Standard Taper-Klemmbuchsen
- Material: Kupplungsnaben Grauguss (EN-GJL-250), Klemmbuchse Stahl

### PRODUCT DESCRIPTION

- For all driving applications concerning mechanical engineering
- Friction-locked solvable shafts/hub connections
- Coupling types TL 1/1; TL 2/2 and TL 1/2 possible
- Application with all standard taper bushes
- Material: Coupling hub cast iron (EN-GJL-250), taper bush steel

TYP SIZE	KLEMBUCHSE TAPER-BUSH	ABMESSUNGEN DIMENSIONS [mm]									GEWICHT BEI MAX. BOHR-Ø WEIGHT AT MAX. BORE Ø [kg]	MASSENTRÄGHEITS- MOMENT J BEI MAX. BOHR-Ø ANGULAR MOMEN- TUM AT MAX. BORE Ø [kg m²]	BEFESTIGUNGSSCHRAUBEN FÜR TAPER-BUCHSE FIXING SCREW FOR TAPER-BUSH			
		A	C	L	L <sub>1</sub> L <sub>2</sub>	E	s	b	G	F			GRÖSSE SIZE [ZOLL]	LÄNGE LENGTH [mm]	AN- ZAHL QUANT.	ANZ.-MT TORQUE [Nm]
28/38	1108	65	65	66	23	20	2,5	15	-	30	1,0	0,0007	1/4"	13	2	5,6
38/45	1108	80	78	70	23	24	3	18	15	38	2,7	0,0030	1/4"	13	2	5,6
42/55	1610	95	93	78	26	26	3	20	16	46	3,0	0,0036	3/8"	16	2	20
48/60	1615	105	103	106	39	28	3,5	21	28	51	4,8	0,0080	3/8"	16	2	20
55/70	2012	120	118	96	33	30	4	22	20	60	4,9	0,0120	7/16"	22	2	31
65/75	2012	135	133	101	33	35	4,5	26	19	68	6,9	0,0140	7/16"	22	2	31
75/90	1) 2517	160	158	144	52	40	5	30	36	80	14,5	0,0650	1/2"	25	2	50
	5/8"												32			90

1) nur lieferbar für TL 1  
2) nur lieferbar für TL 2

1) only available for TL 1  
2) only available for TL 2

TAPER BUCHSEN- GRÖSSE SIZE OF TAPER BUSH	LIEFERBARE BOHRUNGSABMESSUNGEN d1; PASSUNG H7 – PASSFEDERNUTE NACH DIN 6885 BL. 1*																		
	BORE DIMENSIONS AVAILABLE d1; LIMIT AN FIT H7 – KEYWAY ACC. TO DIN 6885 P.1*																		
1108	9	10	11	12	14	16	18	19	20	22	24	25	28*						
1610	14	16	18	19	20	22	24	25	28	30	32	35	38	40	42*				
1615	14	16	18	19	20	22	24	25	28	30	32	35	38	40	42*				
2012	14	16	18	19	20	22	24	25	28	30	32	35	38	40	42	45	48	50	
2517	16	18	19	20	22	24	25	28	30	32	35	38	40	42	45	48	50	55	60
3020	25	28	30	35	38	40	42	45	48	50	55	60	65	70	75				

\*Bohrung mit Passfedernute (flache Ausführung) DIN 6885 Blatt 3

\*Bore with keyway (flat type) acc. to DIN 6885 page 3

### BESTELLBEISPIEL

### ORDER EXAMPLE

KUPPLUNGSGRÖSSE SIZE OF COUPLING	ZAHNKRANZ HÄRTE HARDNESS OF SPIDER [SHORE A]	NABE HUB	FERTIGBOHRUNG FINISH BORE	NABE HUB	FERTIGBOHRUNG FINISH BORE
SOFTX® 42/55	92°	TL 1	Ø 28	TL 1	Ø 38

## SOFTEX®- FA DREHELASTISCHE FLANSCHKUPPLUNGEN SOFTEX® FA ELASTIC FLANGE COUPLINGS

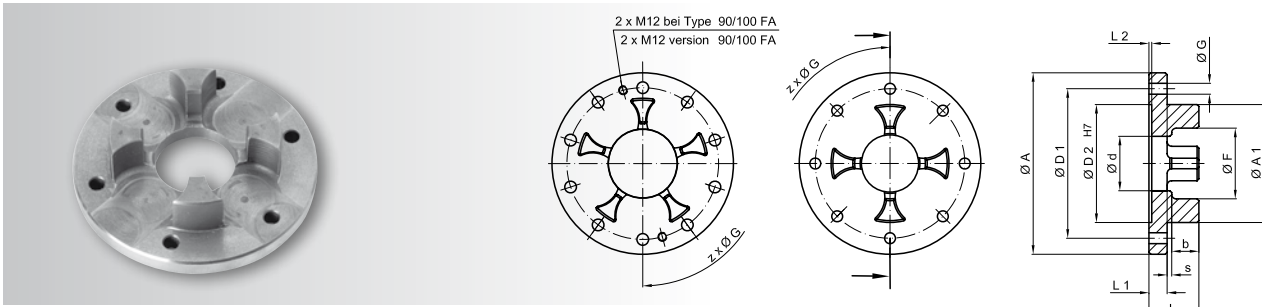

### PRODUKTBESCHREIBUNG

- Flanschnaben für den Schwermaschinenbau
- Alle Größen sind flanschseitig unbearbeitet und montagefertig bearbeitet lieferbar
- 2-Flansche kombinierbar oder FA Flansch mit Standard Softex®-Nabe
- Werkstoff: Grauguss (EN- GJL-250)

### PRODUCT DESCRIPTION

- Flange hubs for heavy machinery
- All sizes are unmachined on the flange side and available ready for assembly
- 2 flanges can be combined or FA flange with standard Softex® hub
- Material: Cast Iron (EN-GJL-250)

TYP SIZE	ABMESSUNGEN DIMENSIONS [mm]													Z ANZAHL QUANTITY	GEWICHT <sup>1)</sup> WEIGHT <sup>1)</sup> [kg]
	A	A <sub>1</sub>	L	L <sub>1</sub>	s	b	F	I <sub>2</sub>	D <sub>1</sub>	D <sub>2</sub>	d	G			
28/38 FA	100	65	27,5	10	2,5	15	39	1,5	80	65	30	7	6	0,55	
38/45 FA	115	80	31	10	3	18	48	1,5	95	80	38	7	6	0,75	
42/55 FA	140	95	35	12	3	20	57	2	115	95	46	9	6	1,35	
48/60 FA	150	105	36,5	12	3,5	21	63	2	125	105	51	9	8	1,55	
55/70 FA	175	120	42	16	4	22	74	2	145	120	60	11	8	2,70	
65/75 FA	190	135	46,5	16	4,5	26	83	2	160	135	68	11	10	3,30	
75/90 FA	215	160	54	19	5	30	98	2,5	185	160	80	14	10	4,90	
90/100 FA	260	200	59,5	20	5,5	34	122	3	225	200	100	14	12	6,70	

1) Gewichte beziehen sich auf den Werkstoff GG.

1) Weights refer to material GG.

### FLANSCHNABEN

Kombinierbare Standardnaben entnehmen Sie bitte der Tabelle auf Seite 4 und alle technischen Daten von Seite 5 und 6. Alle Größen sind auch unbearbeitet ohne die Maße D1-D2-12-G lieferbar.

### FLANGE HUBS

Please consult the table on page 4 for combinable standard hubs and pages 5 and 6 for all technical data. All sizes also available unmachined without dimensions D1-D2-12-G.



Electro ABI B.V.  
Aandrijf- en besturingstechniek  
A. Hofmanweg 60  
2031 BL HAARLEM | HOLLAND  
telefoon: +31(0)23 5319292  
fax: +31(0)23 5326599  
e-mail: info@abi.nl  
www.abi.nl